

Transmission Dimensions

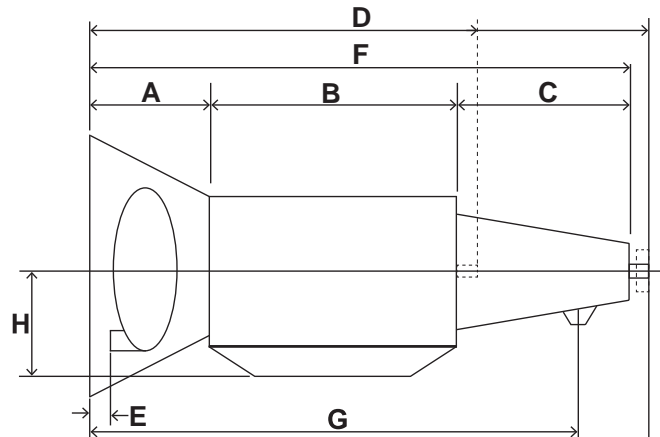

*Units: $\frac{in}{mm}$	A	B	C	D	D	E	F	G	H
Trans Model	Bell Housing	Main Case	Case Extension	Length to Flange	Length to Shaft	Engine Block to Converter Lug	Length to Extension Housing	Engine Block to Mount	Center Line to Bottom Pan
4L60/70 2WD	6.941 176.30	15.421 391.70	8.909 226.30	N/A	30.975 786.75	0.853 21.67	31.272 794.30	24.331 618.00	7.820 198.60
4L60/70 4WD	6.941 176.30	15.421 391.70	4.433 112.60	N/A	26.941 684.30	0.853 21.67	26.795 680.60	24.353 618.56	7.820 198.60
4L80	No separate bell housing	26.01 660.65	5.495 139.57	29.00 (4WD) 736.71	32.1745 (2WD) 817.23	0.893 22.68	31.505 800.23	30.672 771.19	7.80 198.00
6L50	6.181 157.00	16.752 425.50	2.283 58.00	27.559 700.00	26.437 671.50	0.413 10.50	25.216 640.50	25.279 642.10	9.177 233.10
6L80 Fixed Yoke	6.74 171.20	16.468 418.30	3.49 88.66	27.815 706.51	29.089 738.87	0.853 21.67	26.699 678.16	N/A	9.196 233.60
6L80 Slip Yoke	6.74 171.20	16.468 418.30	5.87 149.10	N/A	29.962 761.06	0.853 21.67	30.850 783.60	25.595 650.10	9.196 233.60
6L80 4WD	6.74 171.20	16.468 418.30	3.587 91.10	N/A	26.968 684.98	0.853 21.67	26.795 680.60	25.409 645.38	9.196 233.60
6L90 2WD (Duramax)	7.07 179.63	17.840 453.15	5.629 143.00	N/A	31.439 798.56	0.909 23.10	30.542 775.78	27.480 698.00	9.196 233.60
6L90 4WD	6.74 171.20	17.84 453.15	N/A	28.559 725.42	28.559 725.42	0.853 21.67	N/A	N/A	9.196 233.60

*Dimensions are for typical applications. Dimensions will vary based on converter, bell housing and application. For reference only.

NEW TRANSMISSION REFERENCE

