

TRN8375 - SAE5 RING KIT, STANDARD HARDWARE

BOM #	DESCRIPTION	PCS PART #	QTY
1	LS TO SAE5 ADAPTER RING	TRN7018	1
2	3/8-16 X 1.25" FLANGED HEX BOLT	TRN7540	8

NOTES:

- DO NOT INSTALL ANY DRIVELINE COMPONENTS THAT SHOW MANUFACTURING FLAWS OR SHIPPING / HANDLING DAMAGES.
- APPLY THREADLOCKER TO DRIVELINE BOLTS. CONSULT THE ENGINE MANUAL FOR TORQUE SPECS.
- THIS KIT IS INTENDED FOR USE WITH 4LHD TRANSMISSIONS WITH LS BELLHOUSINGS (SUCH AS TRN4245 OR TRN4345) IN CONJUNCTION WITH THE INSTALLATINO HARDWARE KIT TRN8330.

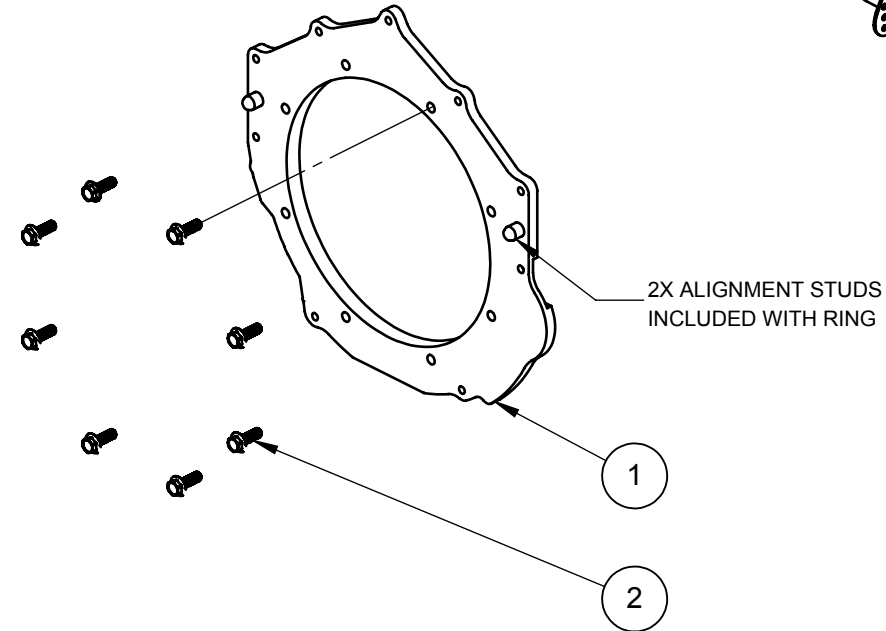

EXPLODED VIEW
PARTS BREAKDOWN
SCALE: 1:8

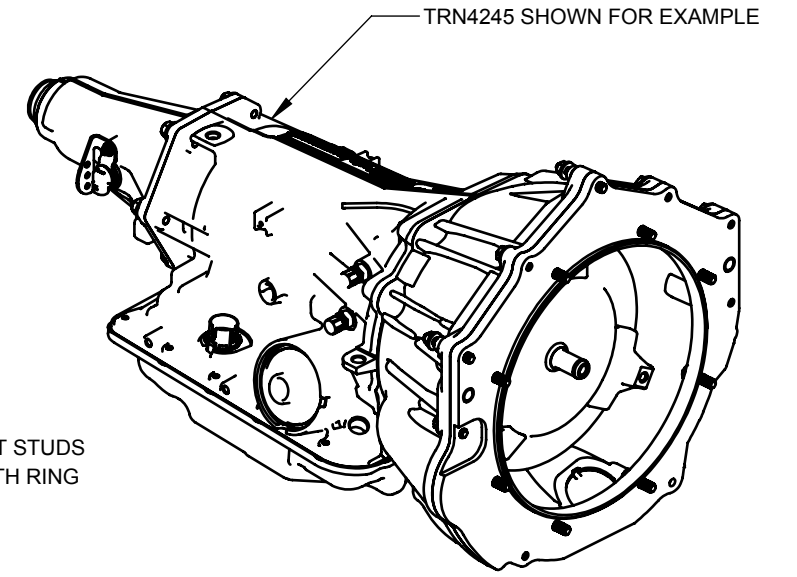

ISO VIEW
SHOWN INSTALLED
SCALE: 1:8

TRN8377 - SAE5 RING KIT, METRIC HARDWARE

BOM #	DESCRIPTION	PCS PART #	QTY
1	LS TO SAE5 ADAPTER RING	TRN7018	1
2	M10X1.5X30mm FLANGED HEX BOLT	TRN7501	8

NOTES:

- DO NOT INSTALL ANY DRIVELINE COMPONENTS THAT SHOW MANUFACTURING FLAWS OR SHIPPING / HANDLING DAMAGES.
- APPLY THREADLOCKER TO DRIVELINE BOLTS. CONSULT THE ENGINE MANUAL FOR TORQUE SPECS.
- THIS KIT IS INTENDED FOR USE WITH 4LHD TRANSMISSIONS WITH LS BELLHOUSINGS (SUCH AS TRN4245 OR TRN4345) IN CONJUNCTION WITH THE INSTALLATINO HARDWARE KIT TRN8330.

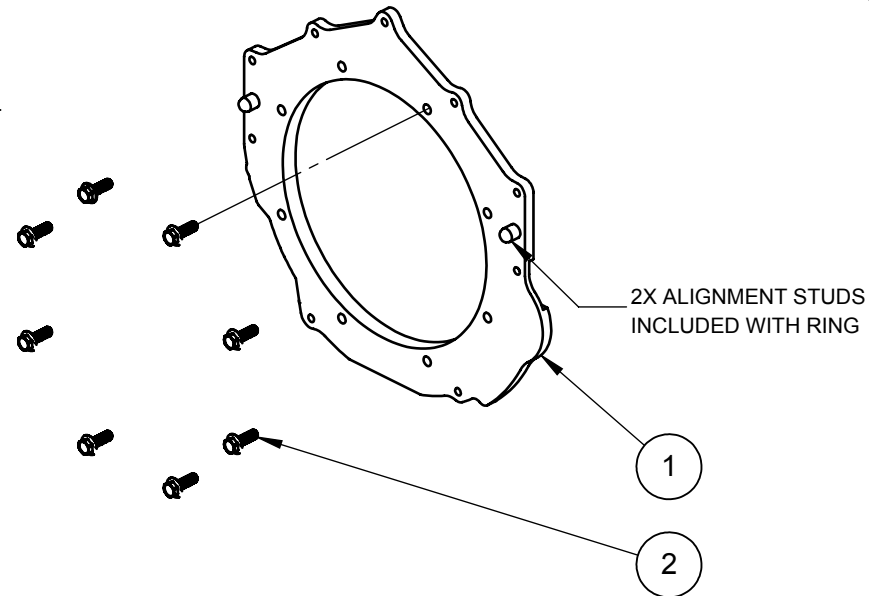

EXPLODED VIEW
PARTS BREAKDOWN
SCALE: 1:8

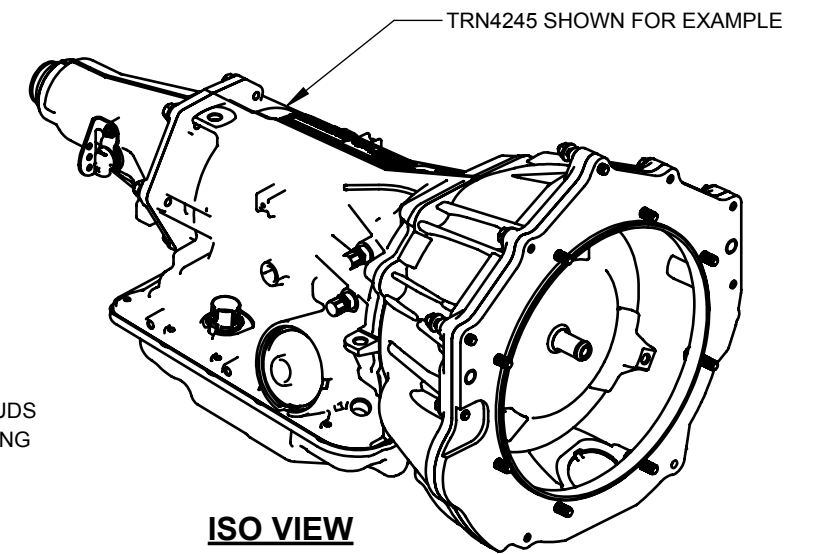

ISO VIEW
SHOWN INSTALLED
SCALE: 1:8



DESCRIPTION	SAE5 RING KITS	
-------------	-----------------------	--

PROPRIETARY AND CONFIDENTIAL
THE INFORMATION CONTAINED IN THIS DRAWING IS THE SOLE PROPERTY OF PCS. ANY REPRODUCTION IN PART OR AS A WHOLE WITHOUT THE WRITTEN PERMISSION OF PCS IS PROHIBITED.

DRAWN BY	MFP	10/13/2017
ENG APPR.		
DIMENSIONS ARE IN INCHES		
SCALE: 1:8	SHEET 1 OF 1	

USED ON	NEXT ASSEMBLY	
SIZE	DRAWING NO.	REV
B	ITEMS SOLD SEPARATELY	1