

PCS Speed Sensor Kit User Guide

Included Components

- 1 - Two Piece Collar with Two Magnets Installed
- 2 - Stainless #8-32 x 1/2" with split lock washers
- 1 - Sensor Bracket*
- 1 - Stainless 3/8"-24 Threaded Body Hall Effect Omni-Polar Speed Sensor with Internal Pul-ip Resistor and two 3/8"-24 Nuts*
- 1 - Harness with 4-pin CPC Mate to Speed Sensor Connector, 10-Foot length, Unterminated End

If any of the above items are missing or replacement parts are needed, please contact Powertrain Control Solutions.

NOTE: Part Number SNS-5004 is designed for use with the Strange Engineering Ford 9" Ultra Case. It does not include a sensor bracket. It replaces the 3/8"-24 sensor with a 5/16"-24.

To accommodate different diameter pinion yokes, various collar diameters are available. These are listed below.

Kit Part Number	Collar Diameter
SNS-5001	2.1875"
SNS-5002	1.875"
SNS-5003 & 04	1.8125"

Installation

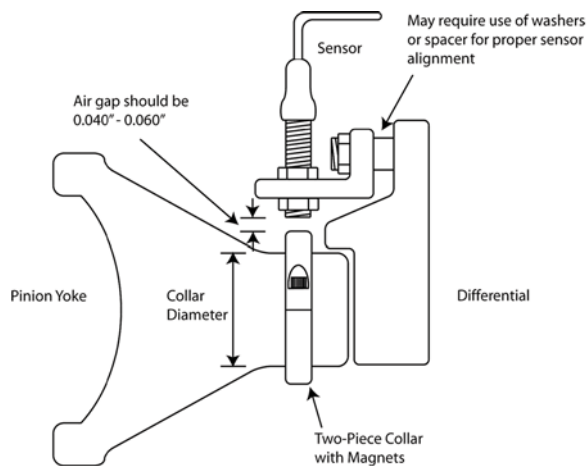

Electrical Connection

The mate to the speed sensor is a 4-way circular plastic connector. The connector and wires are included with the purchase of a sensor. Additional connection kits are available from PCS. The pinout of the speed sensor is shown below.

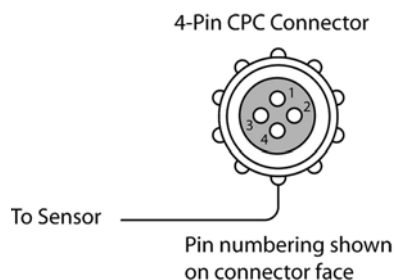

Pin	Function	Wire Color
1	+5V Supply	Red
2	Sensor Output	White
3	Sensor Ground	Black
4	Shield	Bare Metal

NOTE: The speed sensor contains a 2200-ohm internal pull-up resistor between power supply (Pin1) and sensor output (Pin2).

NOTE: The sensor will trigger from either north or south pole magnets.

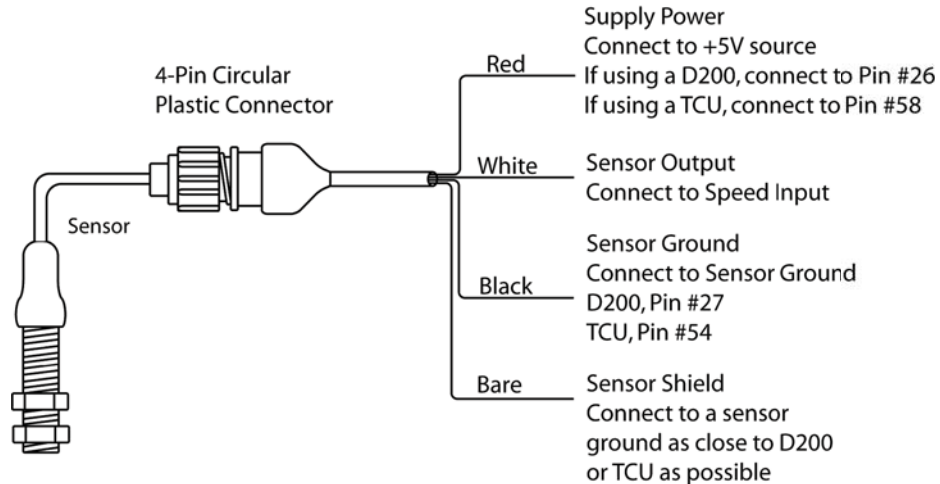

Replacement Parts

This kit includes everything to measure shaft rotation. If replacement magnets or sensors are needed, they can be ordered with the part numbers shown below.

- Magnet Kit - Part #SNS-5010
- Stainless 3/8"-24 Threaded Body Hall-Effect Omni-Polar Speed Sensor with Internal Pull-up Resistor and two 3/8"-24Nuts - Part# SNS-5000

LIMITED WARRANTY STATEMENT. Powertrain Control Solutions, LLC. Warrants all merchandise against defects in factory workmanship and materials for a period of 12 months after purchase. This warranty applies to the first retail purchaser and covers only those products exposed to normal use or service. Provisions of this warranty shall not apply to Powertrain Control Solutions, LLC. Product used for a purpose for which it is not designed, or which has been altered in any way that would be detrimental to the performance or life of the product, or misapplication, misuse, negligence or accident. On any part or product found to be defective after examination by Powertrain Control Solutions, LLC., Powertrain Control Solutions, LLC. will only repair or replace the merchandise through the original selling dealer or on a direct basis. Powertrain Control Solutions, LLC. assumes no responsibility for diagnosis, removal and/or installation labor, loss of vehicle use, loss of time, inconvenience or any other consequential expenses. The warranties herein are in lieu of any other expressed or implied warranties, including any implied warranty of merchantability or fitness, and any other obligation on the part of Powertrain Control Solutions, LLC., or selling dealer.